

INSTRUCTION MANUAL

BS-320AS Dual Mitre, Swivel Head Metal Cutting Band Saw (415V) 510 x 260mm (W x H) Rectangle

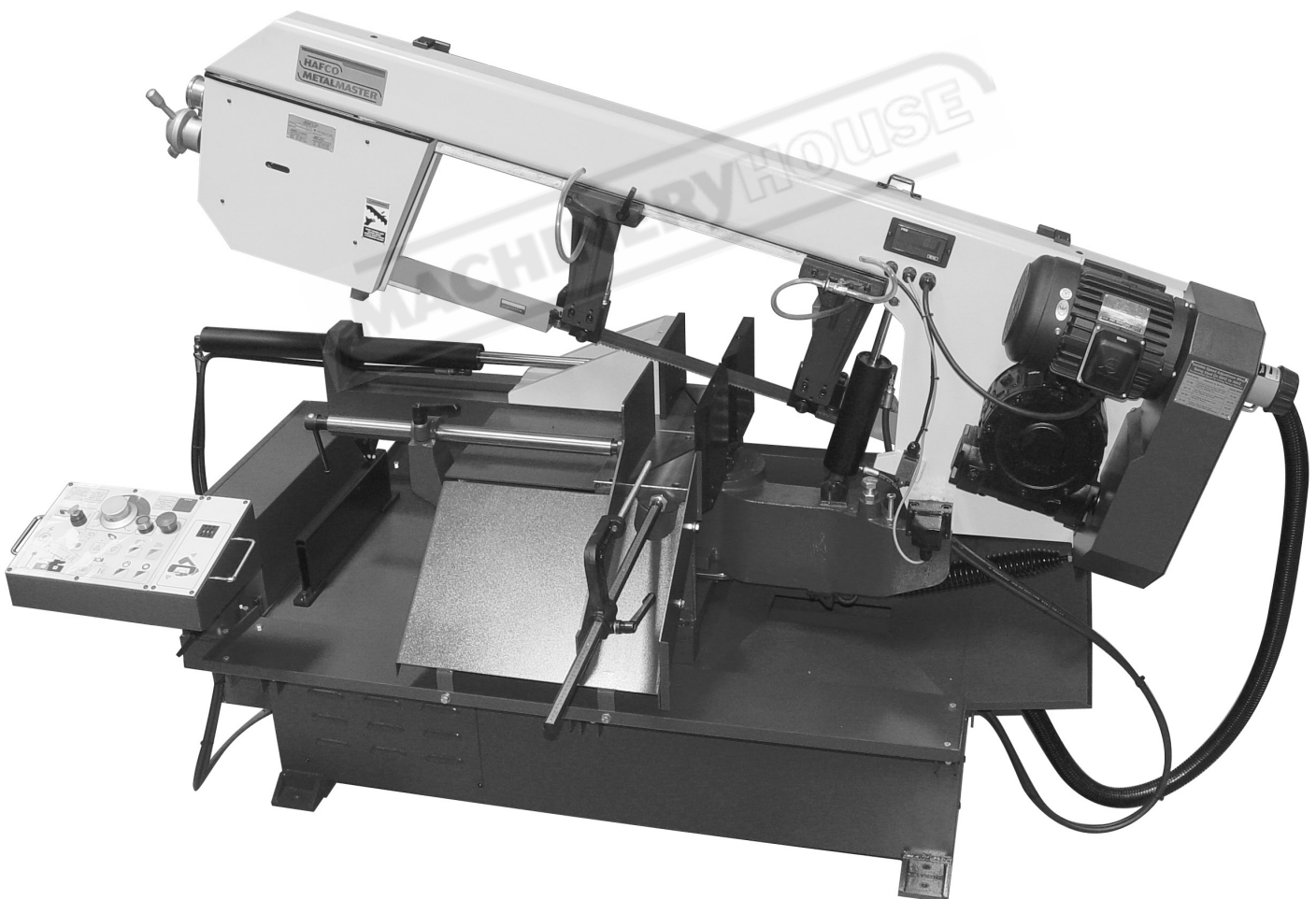

B034

TABLE OF CONTENTS

1	ACCIDENT PREVENTION AND SAFETY REGULATION	1
1.1	Advice for the operator	1
1.2	The electrical equipment according to European Standard "CENELEC EN 60 204-1" which assimilates, with some integrating modifications, the publication "IEC 204-1 (1992)"	1
1.3	Warning labels	1
1.4	Emergencies according to European Standard "CENELEC EN 60 204-1 (1992)"	1
2	MACHINE TRANSPORTATION AND INSTALLATION	2
2.1	Machine dimensions	2
2.2	Transporting the machine	2
2.3	Minimum requirements for housing the machine	2
2.4	Installing the rear coolant return tray	2
2.5	Attaching the retrieving fence	3
2.6	Installing the stop bar	3
2.7	Securing to foundation	3
2.8	Leveling the machine	3
2.9	Deactivation of machine	3
3	DESCRIPTION OF MACHINE PARTS	4
3.1	Control panel	4
3.2	Indicator lights	4
3.3	The saw bow	4
3.4	The vise system	4
3.5	The base	5
3.6	Chip tray	5
3.7	Blade broken micro switch	5
3.8	Chip brush	5
3.9	Blade speed indicator	5
3.10	Speed change dial	5
3.11	Blade angle scale	5
3.12	Attached coolant device	6
4	SET UP AND PRE-OPERATIONS	6
4.1	Adjusting the tungsten carbide guides	6
4.2	Blade tracking adjustment	6
4.3	Placing the saw blade onto the drive wheel and flywheel	6
5	OPERATION PREPARATIONS	7
5.1	Setting the stroke limit	7
5.2	Positioning the vise	7
5.3	Angle cutting	7
5.4	Using the vise and fence	8
5.5	Adjusting the blade speed	8
5.6	Changing the transmission belt	8
5.7	Selecting Automatic and Manual operation	8
5.8	Changing the blade	8
5.9	Laser guide device (optional)	9
5.10	Install the vertical press on the vise jaws for bundle cutting (optional)	9
6	OPERATION CYCLE	10
6.1	Operation cycle	10
6.2	Stopping or emergency stopping	10
6.3	Automatic shutoff during machine operation	10
7	ROUTINE AND SPECIAL MAINTENANCE	10
7.1	Daily maintenance	10
7.2	Weekly maintenance	10
7.3	Monthly maintenance	11
7.4	Six-monthly maintenance	11
7.5	Oils for lubricating coolant	11
7.6	Oil disposal	11
7.7	Special maintenance	11
7.8	Changing gear oil	11
8	TECHNICAL CHARACTERISTICS	11
8.1	Table of cutting capacity and technical details	11
8.2	NOISE TESTS	12

1 ACCIDENT PREVENTION AND SAFETY REGULATION

This machine has been designed to comply with national and community accident- prevention regulations. Improper use and/or tampering with the safety devices will relieve the manufacturer of all responsibility.

1.1 Advice for the operator

- Check, the line voltage is the same as the voltage required by the machine's motor.
- Check the efficiency of your electric supply and grounding system; connect the power cable of the machine to the socket and the ground lead (yellow- green in color) to the grounding system.
- When the machine is in suspended mode (or stopped) the blade must not move.
- Only the blade section used for cutting must be kept unprotected. To remove guards to expose more of the cutting blade adjust the blade guides.
- It is forbidden to use the machine without its shields
- Always disconnect the machine from the power socket before blade change or carrying out any maintenance job, even in the case of abnormal machine operation.
- Always wear suitable eye protection.
- Never put your hands or arms into the cutting area while the machine is operating.
- Do not shift the machine while it is cutting.
- Do not wear loose clothing like: shirts with sleeves that are too long, gloves that are too big, bracelets, chains or any other object that could get caught in the machine during operation. Tie back long hair.
- Keep the area free of miscellaneous object; i.e. equipment, tools, etc...
- Perform only one operation at a time. Never have several objects in your hands at the same time. Keep your hands as clean as possible.
- All internal operations, maintenance or repairs, must be performed in a well-lit area or where there is sufficient light from extra sources to avoid the risk of accidents.

1.2 The electrical equipment according to European Standard" CENELEC EN 60 204-1" which assimilates, with some integrating modifications, the publication "IEC 204-1 (1992)"

- The electrical equipment ensures protection against electric shock as a result of direct or indirect contact. The active parts of this equipment are housed in a box to which access is limited by screws that can only be removed with a special tool; the parts are fed with alternating current as low voltage (24V). The equipment is protected against splashes of water and dust.
- Protection of the system against short circuits is ensured by means of rapid fuses and grounding; in the event of a motor overload, protection is provided by a thermal probe.

- In the event of a power cut, the specific start-up button must be reset.
- The machine has been tested in conformity with point 20 of EN 60204

1.3 Warning labels



Replace warning labels if they become obscured or removed.

- Keep hands and other body parts away from a running blade.
- Do not open the blade cover while machine is running.
- Do not store combustible materials near or around machine.
- Always wear approved safety glasses/face shields while using this machine.
- Keep machine guards in place at all times.
- Do not wear gloves.
- Remove loose clothing and confine long hair.
- Keep the work area clean and free miscellaneous objects.

1.4 Emergencies according to European Standard "CENELEC EN 60 204-1 (1992)"

- In the event of incorrect operation or a danger condition, the machine may be stopped immediately by pressing the red mushroom shaped button.

NOTE: Resetting of machine operation after each emergency stop requires resetting the emergency stop button.

2 MACHINE TRANSPORTATION AND INSTALLATION

2.1 Machine dimensions

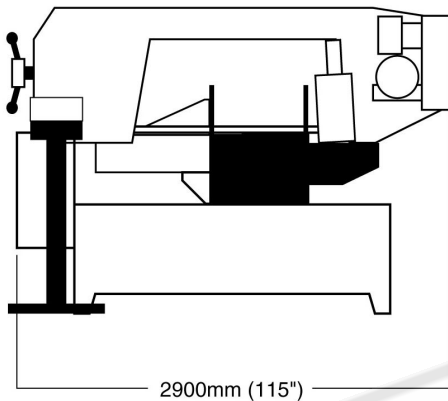
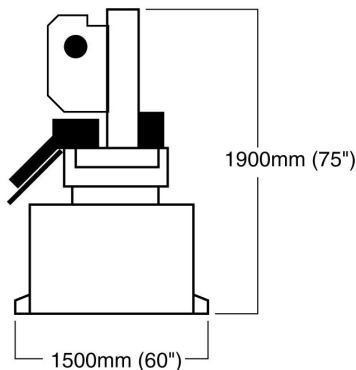

2.2 Transporting the machine

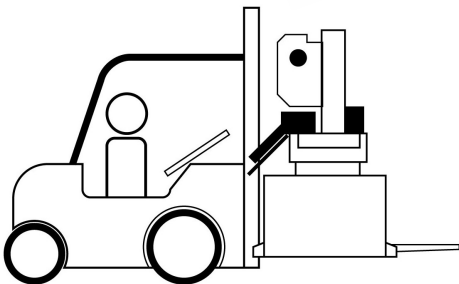

Unpack your machine carefully, and use a forklift to set it in position. If a crane is used to lift the machine, attach the lifting cable carefully to the machine. Sufficient space should be left around the machine to allow safe handling of materials, inspection, and maintenance operations. Take precautions to choose a location that will keep the machine free of vibration and dust caused by other machinery.

2.3 Minimum requirements for housing the machine

- Main voltage and frequency must comply with the machine's motor requirements.

- Environment temperature should fall within (-10°C to + 50 °C).
- Relative humidity cannot be over 90%.

2.4 Installing the rear coolant return tray

The rear coolant-return tray must be installed after the machine is set in place. Install the coolant return trays first.

Installing three channeled L-bracket

Install three channeled L-bracket to the back of the machine stand. Attaching the brackets requires 6 hex head bolt, 6 spring washers, 6 washers, and 6 nuts.

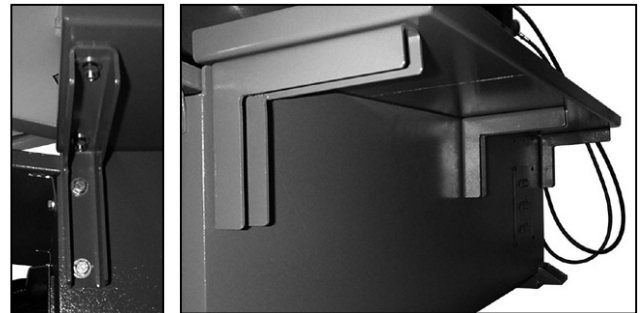

- Place a spring washer and washer on each hex head bolt.
- Face the long side of the bracket up.
- Align the holes of short side of the bracket to the machine panel's holes.
- Place the 2 hex head bolts and their washers through each bracket and machine panel.
- Use a nut on the inside of the machine stand to secure each hex head bolt.

securing the rear tray

Attaching the trays requires 6 hex head bolt, 6 spring washers, 6 washers, and 6 nuts.

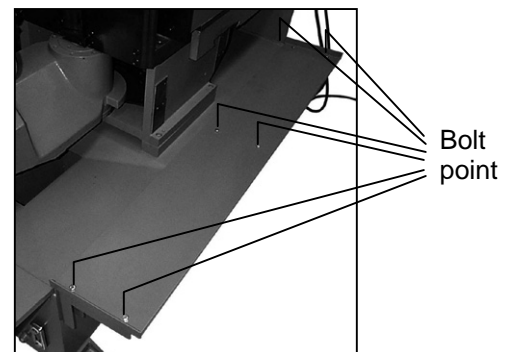

- Arrange the tray rims to facing up and away from the machine.
- Place the rear return tray onto brackets at the back of the machine.
- Align the holes of the rear tray and the six-channeled L-brackets.
- Place 6 hex head bolts through the holes of the trays and brackets.
- Secure each hex head bolts with a washer, spring washer, and hex nut.

2.5 Attaching the retrieving fence

The vise fence aids in redirection and retrieval of material. This may need to be adjusted or removed for some angle cutting operations.

- Unlock swiveling control panel lock handle to rotate the control panel out of the machine base.



- Loosen the retrieval device lock handle and move it forward to the limited then lock the handle.

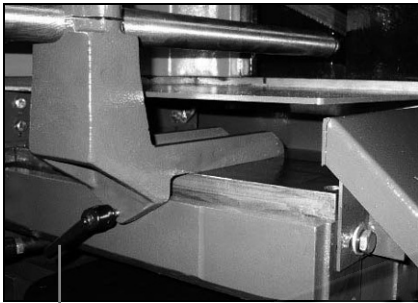

Retrieval device lock handle

- Attach the mobile fence to the retrieving vise rod.
- Tighten the setscrew to secure.

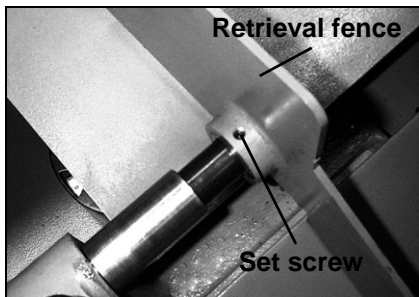

- The picture is done after adjusting and installing.

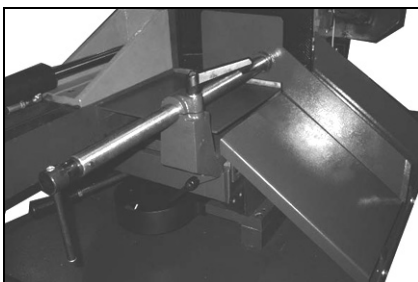

2.6 Installing the stop bar

Screw in the stop bar (long rod) by rotating it clockwise into the treaded hole on the bench just below the vise. Place the work stop bracket onto the stop bar and tighten the lock handle. Attach the stop screw to the stop bracket with nut and tighten it.

2.7 Securing to foundation

Position the machine on a flat and level foundation of reinforced concrete. Level machine and anchor it to the foundation with anchor bolts. Maintain a minimum distance of 800mm from the rear of the machine to the wall. Position the anchors using screws and expansion plugs or tie rods sunk in cement.

2.8 Leveling the machine

The operating accuracy of all precision machinery depends on the accuracy of the installation of the machine. Manufacturing tolerance of the machine can only be guaranteed if the machine is firmly and properly installed. Once the machine is lowered on the prepared foundation, machinist levels should be used alternately on the vice slide plates and work feed table, adjust the left to right and front to back level of the machine with leveling bolts.

- When leveling left to right level, adjust left side to be approximately 3mm higher than the level of the right side. This will provide proper return of the cutting fluid. After proper leveling of the machine, use anchor bolts to secure to the foundation. Caution: All leveling bolts should support the weight the machine evenly.

2.9 Deactivation of machine

If the machine is to be out of use for a long period, it is advisable to proceed as follows:

- 1) Disconnect from the power supply
- 2) Loosen the tension on the blade
- 3) Release the bow return spring
- 4) Empty the coolant tank
- 5) Carefully clean and grease the machine
- 6) If necessary, cover the machine.

Dismantling (due to deterioration and/or obsolescence)

As a General Rule,

If the machine is to be permanently demolished and/or scrapped, divide the material to be disposed of according to type and composition, as follows:

- 1) Cast iron or ferrous materials, composed of metal alone, are secondary raw materials, so they may be taken to an iron foundry for re-smelting after having removed the contents (classified in point 3).
- 2) Electrical components, including the cable and electronic material (magnetic cards, etc.), fall within the category of material classified as being assimilated to urban waste according to the laws of your local, state, or federal

government, so they may be set aside for collection by the public waste disposal service;

- 3) Old mineral and synthetic and/or mixed oils, emulsified oils and greases are considered hazardous or special refuse, so they must be collected, transported and disposed of at a special waste disposal service.

NOTE: The standards and legislation concerning refuse is in a constant state of evolution, therefore is subject to changes. The user must keep informed of the regulations at the time of disposal as these may differ from those described above.

3 DESCRIPTION OF MACHINE PARTS

3.1 Control panel

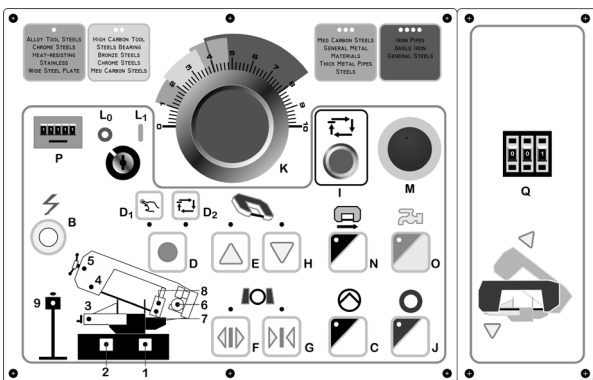

- A. Main connect switch – main power
 B. Main power indicator light – indicates that main power is active
 C. Hydraulic flow control start switch – activates hydraulic power
 D. Operation mode switch – selects either automatic or manual operation mode.
 D1. Manual operation mode – press switch D until the manual mode's indicator light shows up.
 D2. Automatic operation mode – press switch D until the automatic mode's indicator light shows up.
 E. Bow up switch – press to raise the saw bow
 F. Vise open switch – press to open the vise
 G. Vise close switch – press to close the vise
 H. Bow down switch – press to lower the saw bow
 I. Cycle start switch – press to begin operation
 J. Stop switch – press to stop operation cycle and return to start position
 K. Cutting feed rate – adjust the rate of cutting of the saw bow.
 L. Key lock power switch – to start or stop power.
 L0. Power off switch – key switch to turn power off
 L1. Power on switch – key switch to turn power on
 M. Emergency Stop Button – Press to stop all machine functions
 N. Blade tracking switch – press to activate blade tension and set the blade tracking.
 O. Coolant start switch – press to activate or stop coolant flow

- P. Counter – counts the pieces cut, press the button to reset units to zero.
 Q. Stroke height switch – limits the stroke height to eliminate the wasted motion and time. Maximum height limit is 330mm (13”).

3.2 Indicator lights

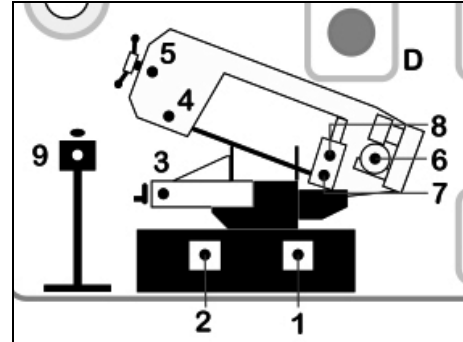

1. Coolant pump warning light
 2. Hydraulic pump warning light
 3. Vise pressure warning light
 4. Open blade cover warning light
 5. Broken blade warning light
 6. Main motor warning light
 7. Lower stroke limit indicator light
 8. Upper stroke limit indicator light
 9. Emergency stop indicator light

3.3 The saw bow

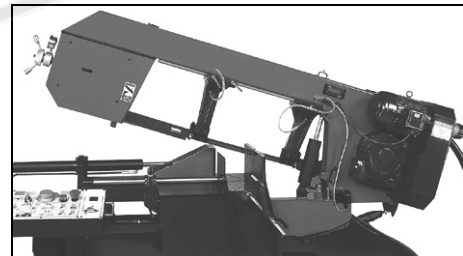

Machine parts consisting of drive members (gear motor, variable speed motor, and flywheels), tightening and guide (blade tightening slide, blade guide blocks) of tool.

3.4 The vise system

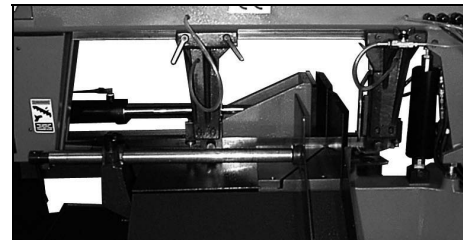

This machine requires the use of two vises to perform the hydraulic feed operation. The vise system consist of a hydraulic vise for clamping work material. Each of the vises has a miter slot, which is good for the right or left side's angle cutting to 60°.

3.5 The base

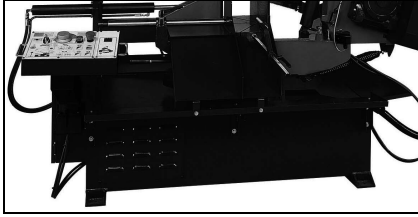

The base is the structure supporting the saw bow (the bow pivot point and respective blocking system), the vises, and containing chip tray and coolant system.

3.6 Chip tray

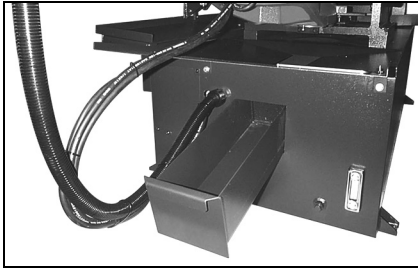

Removable chip tray for capture of chips and debris.

3.7 Blade broken micro switch

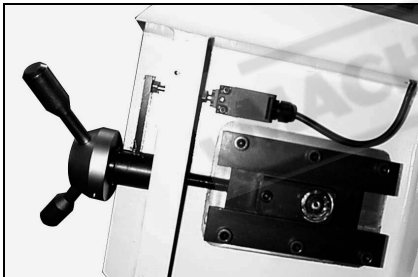

This machine is equipped with automatic power shut-off safety device to prevent any further damage when a blade has been broken. There is a reduction in tension when an adjustment bolt actuates micro switch's plunger. To keep the micro switch in proper contact with the blade's tension. An adjustment of the actuator bolt is required.

3.8 Chip brush



This model has a powered chip brush driven by an axle transfer from the drive wheel. The chip brush is designed to clean the blade thus prolonging the life of the blade.

3.9 Blade speed indicator

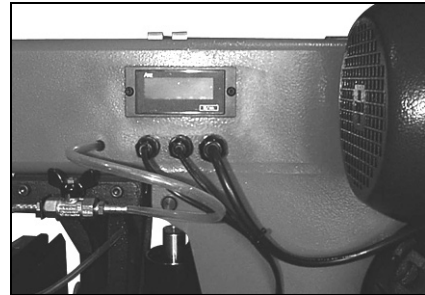

A digital display indicates the blade speed in MPM (FPM). This works in conjunction with speed changing dial to give you precise control of blade speed.

3.10 Speed change dial

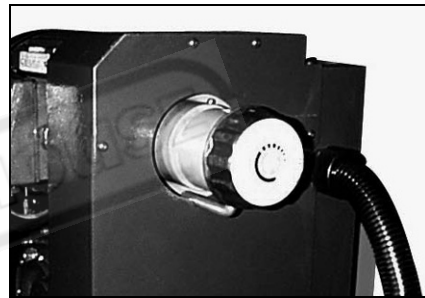

The speed change dial adjusts the variable speed transmission so that there is a change in blade speed. Change only while blade is moving.

This machine has a variable speed transmission using a variable pulley - system. The speed is changed by rotating the speed changer dial to adjust the width of the pulley discs. When compressed, the pulley discs cause the belt to ride the outer edge of pulley discs and changing the speed. The speed must be changed while belt is moving.

3.11 Blade angle scale

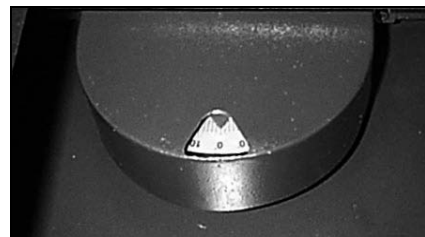

The scale indicates the cutting angle of the blade. The scale has preset stops at every 15°.

3.12 Attached coolant device

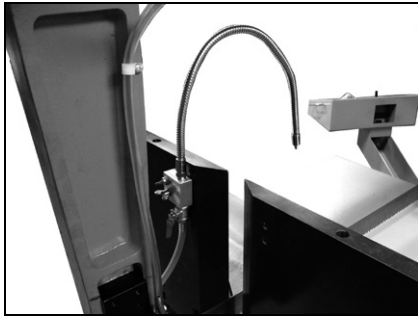

An attached coolant device that is screwed on the front vise jaw for supply enough coolant to the cutting material. This device can be unscrewed, and move to the rear vise jaw for easy both side miter cutting.

4 SET UP AND PRE-OPERATIONS

4.1 Adjusting the tungsten carbide guides

The blade is guided by the upper ball bearings, side ball bearings, and tungsten carbide guides.

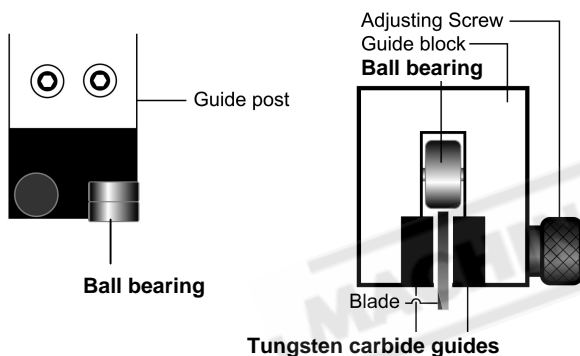

- When ready to cut the work piece, the carbide guide must be adjusted by adjusting the screws to properly compressed blade. The tungsten carbide blades should touch, but not pinch the blade.
- For moving the blade guide posts or changing blade, the tungsten carbide guides should be released by using the adjusting screw.

In case the blade needs to be replaced, make sure to always install 1.1mm (0.043") thick blade.

4.2 Blade tracking adjustment

This adjustment must be accomplished by qualified personnel that are familiar with this type of adjustment and the dangers associated with it.

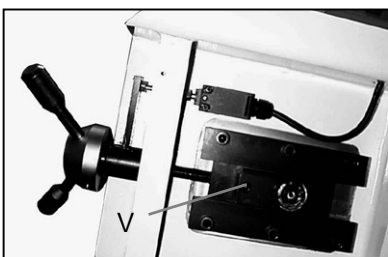

Blade tracking has been set at the factory and has no adjustment required. If a tracking problem occurs, adjust the machine as follows:

- Raise saw arm to the proper position.
- Locate tracking adjustment screw (V) on the front of the saw blade, flywheel side.
- Reduce the blade tension a little.
- Turn the tracking adjustment screw (V) to adjust the saw blade ride.
- Retension the blade tension.
- Connect the machine power to run the blade for 1-2 minutes. Then stop the machine operation.
- Remove the blade guides and open covers to check the blade tracking
- Close covers, replace the blade guides and tighten the setscrews.
- If necessary, readjust it again.

4.3 Placing the saw blade onto the drive wheel and flywheel

- Disconnect from power supply
- Remove the blade guards
- Turn the blade tension handle counter-clockwise, to fully loosen the flywheel.
- Open the blade cover and place the saw blade onto the race of the drive wheel and flywheel.
- *Check the cutting direction of the saw blade.
- Insert the saw blade into the rollers of the left and right blade guide.
- The back edge of the saw blade should make contact with the flange of the drive and flywheel; turn clockwise the blade tension handle to tighten the saw blade, until the blade is properly tensioned.
- Replace the blade guards.
- Use the blade running switch 3.1N to check the proper ride of the blade.

4.4 Hydraulic vise pressure

The hydraulic pressure gauges for the vise located on the rear of the base.

Located just below the gauge is the pressure adjuster knob. It allows for the reduction of hydraulic pressure clamping force. The normal pressure is set at 35kgs/cm². This is good for most solid firm materials. For softer, hollow, or pipe materials using 20-25kgs/cm² is good. Different materials may require different clamping force.

In auto mode, the vise pressure can be changed by turning the pressure knob (Z), when it has clamped the workpiece.

- Unlock the fluted knob nut (Z1).
- Turn the fluted knob (Z) counterclockwise to decrease the pressure, clockwise to increase the vise pressure.
- Lock the fluted knob nut after adjusting.

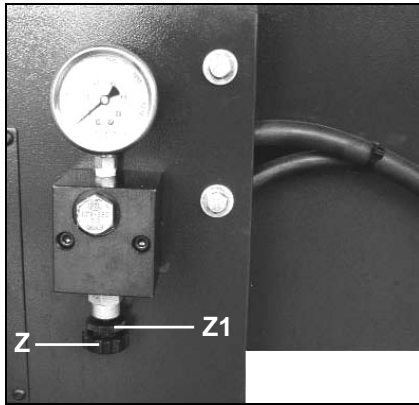

5 OPERATION PREPARATIONS

5.1 Setting the stroke limit



Q

This machine is equipped with a numeral switch Q to set the saw bow an efficient return height. If cutting lots of pieces, set the saw bow's return stroke height switch according to the work-piece's diameter will reduce the overall time of one operation cycle.

5.2 Positioning the vise

When cutting angles, the relocation of the vise and fence are necessary to prevent the blade from cutting either the hydraulic vise or mobile retrieving fence.

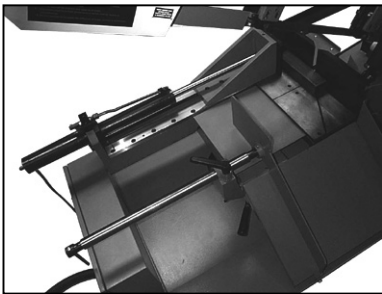

Adjusting the hydraulic vise for angle cutting

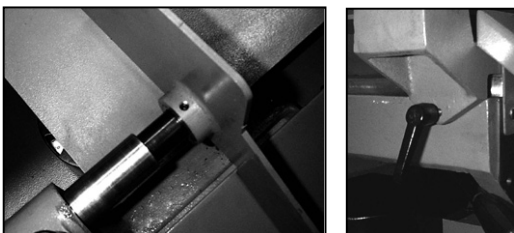

- Disconnect power.
- Loosen the hex socket head screw on the mobile retrieving fence.
- Remove the mobile retrieving fence.
- Detach the retrieving ramp by unscrewing the 2 bolts connecting it to the bench and the 2 bolts connecting it to the tray.
- Unlock the retrieving vise by using the lock handle.
- Slide the retrieving vise off the track and set aside.

Position the hydraulic vise closer to the retrieving ramp side, remembering to allow clearance of the saw bow and blade.

- The saw bow must be raised to clear the vise.

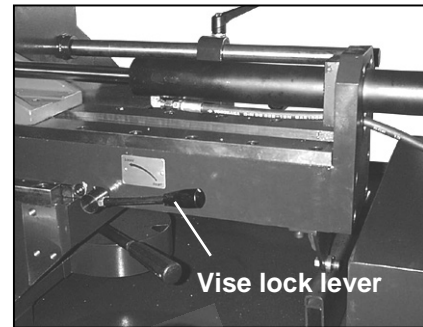

- Unlock the hydraulic vise lock lever.
- Push the hydraulic vise toward the retrieving table.
- Visually check clearance of the blade and saw bow against the hydraulic vise. Readjust the position if necessary.
- Lock the hydraulic vise in to the position using its lock handle.

5.3 Angle cutting

The machine can cut angles up to 60° in both directions

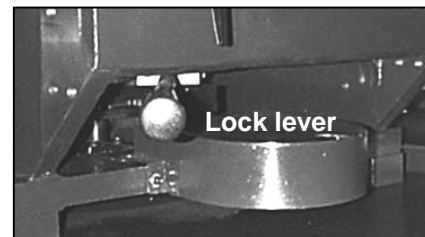

- Check that the saw bow is raised to clear the vise fixed vise jaw.
- Turn off power.
- Unlock the saw bow by using the lock lever under the machine bench.
- Rotate the saw bow to the desired cutting angle. Refer to the scale to determine the proper angle.
- Lock the cutting angle in place by using the lock lever.
- Next, adjust the location of the vise or fence to avoid contact with the blade.

5.4 Using the vise and fence

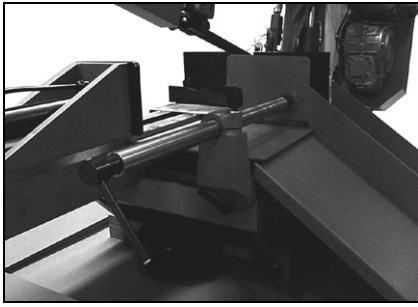

The hydraulic vise operates automatically and can be controlled using the control panel. Use the vise open switch 3.1F and vise close switch 3.1G to open and close the vise. Power must be active. Hydraulics must be active.

The retrieval vise can function as a secondary vise as well as guiding cut material. Use the top lock handle to lock the fence near the material. Use the handle on the shaft of the vise to quick clamp and unclamp the vise a short distance. Remove for retrieving ramp side angle cutting.

5.5 Adjusting the blade speed

*Blade speed must be changed while belt and blade are moving.

- Check that the machine is running and blade is moving.
- Rotate the speed change dial 3.10 and check the speed indicator 3.9 for desired speed. Turn the dial clockwise to raise blade speed, and turn the dial counter clockwise to reduce blade speed. The speeds available are 26-80MPM (85-262FPM) (50Hz), 32-96MPM(105-315FPM) (60Hz).

5.6 Changing the transmission belt

Over time and due to normal wear and tear the pulley belt will need to be changed.

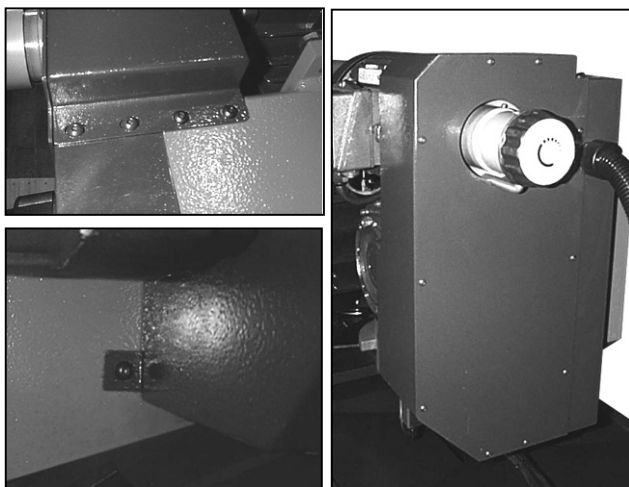

- Disconnect the machine from power supply.
- Open the belt cover. Remove 4 screws from the top. Remove 1 screw from the front. Remove 8 screws from the cover.
- Turn the dial counter-clockwise to open the pulley discs and loosen the belt.

- Replace the belt.
- Turn the dial to pretension the belt.

5.7 Selecting Automatic and Manual operation

- To select manual mode, press operation mode switch 3.1 D.
- Check the indicator light 3.1 D1 lightening.
- To select hydraulic operation, press operation mode switch.
- Check the indicator light 3.1 D2 lightening.

5.8 Changing the blade

WARNING

Disconnect the machine from the power source before making any adjustments or repairs! Failure to comply may result in serious injury!

- Raise the saw bow approximately 6" in height.
- Disconnect the machine from the power source.
- Remove both blade guides from the blade guide blocks and cover.
- Loosen the cover's lock screws and open the covers.
- Take off the chip brush device by loosen it's screws.
- Loosen left blade guide arm's lock handles and slides it to the right side as far as possible.
- Release blade tension by turning the blade tensioning handle counter-clockwise until blade is free.
- Remove the old blade from both wheels and out of each blade guide.

 Caution: Even dull blades are sharp to the skin! Use extra caution handling band saw blades!

- Position the blade and making sure that the teeth are pointed downward in the cutting direction.
- Position the blade on the wheels. Make sure back of the blade rests lightly against the wheel flange of the both wheels. Twist blade slightly to allow it to slip into guides.
- Tension the blade tension to the tension line as indicator shown 331DSA by turning the handle clockwise. Replace the chip brush device so that it touches the blade and tighten setscrew.

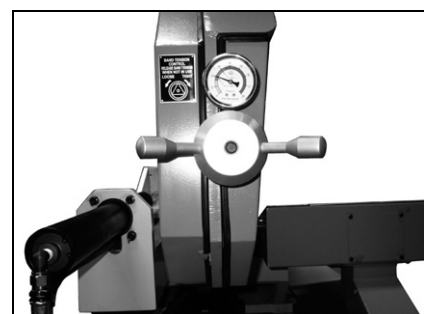

- Close all covers and guards and fasten securely. Connect machine to power and run the blade freely for 1-2 minutes.
- Turn the power off and recheck the blade tension and chip brush. If further adjustment is necessary disconnect the saw from the power source, make adjustments, and re-connect the power.

5.9 Laser guide device (optional)

The laser guide has been set correctly before shipment. The laser guide - line works when machine power on, the red line will align and close with the blade.

if any situations have to readjust Laser device, see below pictures.

- A screw for moving the device forward or backward.
- B screw for moving the device downward or upward.
- Loosen C thumb knob for adjust the device angle.

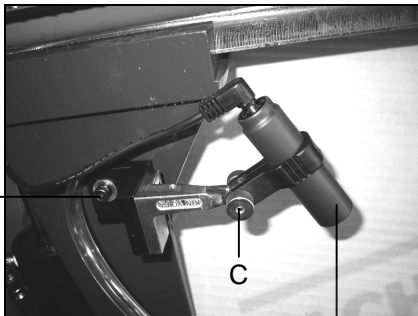

Laser guide device

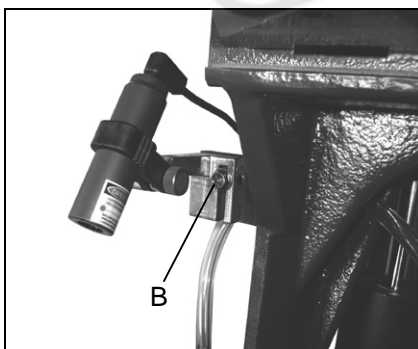

5.10 Install the vertical press on the vise jaws for bundle cutting (optional)

- Standard press capacity (W x H)
250~500x50~200 mm.
Vise plates height 160 mm
- Special press capacity (W x H)
250~485x200~350 mm.
Vise plates height 300 mm

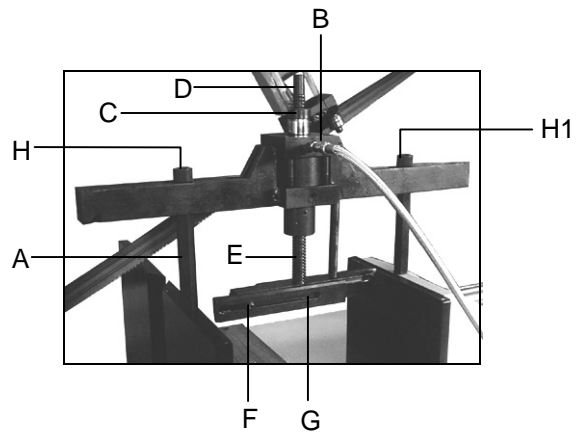

- Open the vise more than 250mm.
- Attach and Tighten posts bolts' (A) on to vises. Then attach the vertical press to the top of the post bolts. Connect the Hydraulic connector (B).
- Attach the nuts (H) on to the posts, but do not make the nut (H1) on moveable vise jaw too tight. *Otherwise, the vise won't be able to clamp the work piece or the post bolts will be damaged.
- Adjust the vise press (E) to sit approximately 5-8mm above the work piece. Loose nut (C) and rotate the bolt (D) to raise or lower the vise press (E).
- Adjust the vise press width to fit the work piece size. Loosen screws (F) on both sides of the vise press then move press extender bars (G) desired width.

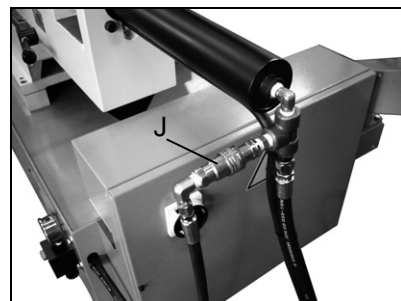

- Turn OFF the hydraulic pump.
- Attach the hydraulic hose to connector (B) and then attach the quick link connector (J) to the 90-degree fitting.
- Switch ON the hydraulic pump.

6 OPERATION CYCLE

6.1 Operation cycle

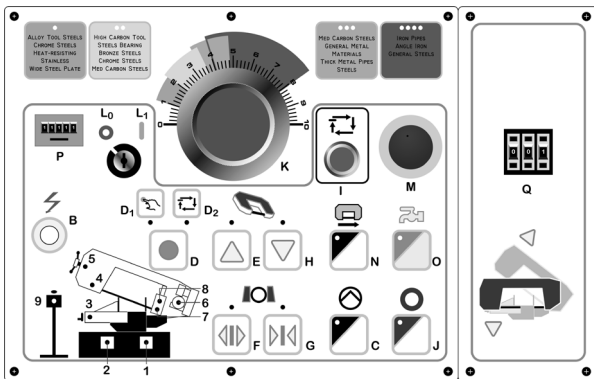

- Turn on the main connect switch A. on the door of electrical box.
- Turn the key to automatic operation mode L1 to unlock the machine. The indicator light B should be lit.
- Start the hydraulic system, use switch C.
- Press the selector D to manual operation mode D1, and its indicator light will be lit.
- Raise the saw bow, Use bow up switch E.
- Open the vise, use vise open switch F.
- Load the working material.
- Secure the material, use the vise close switch G.
- Base on the diameter of the material; set the saw bow's height Q.
- Choose the blade speed appropriate for the material.
- If cutting many pieces, set the saw bow return stroke height.
- Select the operation cycle mode 6.1 D2 to press the selector 6.1 D. The indicator light will be lit.
- Restart the hydraulic system. Press the hydraulic start switch 6.1 C.
- Start operation by using the start switch 6.1 I.
- The digital display 6.1 P will present pieces cut.
- When the cutting operation is finished the saw bow will automatically rise to the preset height ready for the next operation.

6.2 Stopping or emergency stopping

There are two ways to stop the machine in an event of an emergency or improper operation.

- For most situations, use the stop switch 6.1 J. Using the stop switch 6.1 J will not reset the controls and your operation setting. The blade and drive motor will stop. Then the saw bow will rise to the start position. Adjustments can be made.
- Use the cycle start switch to continue the cutting cycle.
- For unsafe and emergency conditions use the emergency stop button 6.1 M. Using emergency stop button 6.1 M will stop the machine in last position. The motor and hydraulic will stop and control setting will be reset.

- To restart, the emergency stop button 6.1 M must be turned to release from the pressed position. Then the operation cycle 6.1 must be restarted.

6.3 Automatic shutoff during machine operation

If there are any improper operation or situation, the machine is designed to automatically shut off during the operation cycle to prevent any further damage from occurring.

- If the hydraulic pump is on and the machine has not been active for 5 minutes, the power will be shut off.
- If the time take to clamp the vise is over 40 sec, the power will shut off. The vise pressure warning light will flash in warning.
- After cutting the saw bow has taken more than 40 sec to rise to the start position, the power will shut off. The upper stroke-limit indicator light will flash in warning.
- After pressing the start button, the vise clamps the work piece, and saw bow begins cutting. If the cutting time is unable to finish within 90 minutes, the lower stroke limit indicator will flash in warning and the power will be shut off.

If any of the above situations occurs, reset the machine by pressing 6.1D. This will change the operation mode – manual or automatic.

7 ROUTINE AND SPECIAL MAINTENANCE

The maintenance jobs are listed below, divided into daily, weekly, monthly and six-month intervals. If the following operations are neglected, the result will be premature wear of the machine and poor performance.

7.1 Daily maintenance

- Give general cleaning to the machine to remove accumulated shavings.
- Clean the lubricating coolant drain hole to avoid excess fluid.
- Top off the level of lubricating coolant.
- Check blade for wear.
- Rise of saw frame to top position and partial slackening of the blade to avoid useless yield stress.
- Check functionality of the shields and emergency stops.

7.2 Weekly maintenance

- Thoroughly clean the machine to remove shavings, especially from the coolant tank.
- Removal of pump from its housing, cleaning of the suction filter and suction zone.
- Clean the filter of the pump suction head and the suction area.
- Use compressed air to clean the blade guides (guide bearings and drain hole of the lubricating cooling).
- Clean flywheel housings and blade sliding surfaces on flywheels.

7.3 Monthly maintenance

- Check the tightening of the drive wheel screws.
- Check that the blade guide bearings on the heads are perfect running condition.
- Check the tightening of the screws of the motor, pump, and accident protection guarding.

7.4 Six-monthly maintenance

- Test the continuity of the equipotential protection circuit.

7.5 Oils for lubricating coolant

Considering the vast range of products on the market, the user can choose the one most suited to their own requirements, using as reference the type SHELL LUTEM OIL ECO. THE MINIMUM PERCENTAGE OF OIL DILUTED IN WATER IS 8 - 10 %.

7.6 Oil disposal

The disposal of these products is controlled by strict regulations. Please see the Chapter on "Machine dimensions Transport - Installation" in the section on Dismantling.

7.7 Special maintenance

Special maintenance must be conducted by skilled personnel. We advise contacting your nearest dealer and/or importer. Other protective and safety equipment, devices (of the reducer), the motor, the motor pump, and other electrical components also require special maintenance.

7.8 Changing gear oil

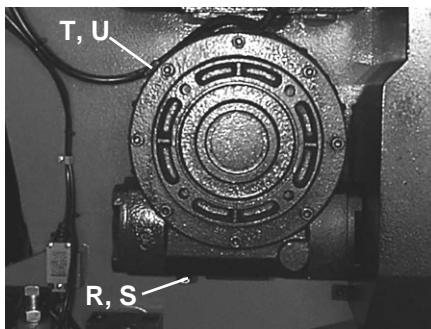

The gear box requires periodic changing of oil. The oil must be changed by the first 6 months of a new machine and every year thereafter.



- To change the gear box oil
- Disconnect the machine from the power source.
- Raise the saw arm to vertical position
- Release the drain hold (R) to draw off gear oil by loosening the hex head screw (S).
- open fill hole (T) by releasing hex head screw (U)
- Replace the screw (S) after oil completely flows off.
- Replace hole using the fill hole (T).
- Replace hex head screw (U)

8 TECHNICAL CHARACTERISTICS

8.1 Table of cutting capacity and technical details

Cutting Capacity			
0°	331mm	320mm x 485mm	260mm x 510mm
45	315mm	315mm x 315mm	
60	215mm	195mm x 315mm	

Electric motor-blade rotation	2.2kW
Reduction unit in oil bath	40:1L
Blade Dimentions	34mmx 1.1mm x 4180mm
Blade speed cutting	32-96MPM
Coolant tank volume	52L
Hydraulic tank volume	12L
Machine weight	1000kgs
Floor space 90°	2900mm x 1500mm x1900mm
Floor space 60°	2900mm x 2100mm x1900mm

TYPES OF STEEL						CHARACTERISTICS		
USE	I UNI	D DIN	F AF NOR	GB SB	USA. AISI-SAE	Hardness BRINELL HB	Hardness ROCKWELL HRB	R=N/mm ²
Construction steels	Fe360	St37	E24	----	----	116	67	360÷480
	Fe430	St44	E28	43	----	148	80	430÷560
	Fe510	St52	E36	50	----	180	88	510÷660
Carbon steels	C20	CK20	XC20	060 A 20	1020	198	93	540÷690
	C40	CK40	XC42H1	060 A 40	1040	198	93	700÷840
	C50	CK50	----	----	1050	202	94	760÷900
	C60	CK60	XC55	060 A 62	1060	202	94	830÷980
Spring steels	50CrV4	50CrV4	50CV4	735 A 50	6150	207	95	1140÷1330
	60SiCr8	60SiCr7	----	----	9262	224	98	1220÷1400
Alloyed steels for hardening and tempering and for nitriding	35CrMo4	34CrMo4	35CD4	708 A 37	4135	220	98	780÷930
	39NiCrMo4	36CrNiMo4	39NCD4	----	9840	228	99	880÷1080
	41CrAlMo7	41CrAlMo7	40CADG12	905 M 39	----	232	100	930÷1130
Alloyed casehardening steels	18NiCrMo7	----	20NCD7	En 325	4320	232	100	760÷1030
	20NiCrMo2	21NiCrMo2	20NCD2	805 H 20	4315	224	98	690÷980
Alloyed for bearings	100Cr6	100Cr6	100C6	534 A 99	52100	207	95	690÷980
Tool steel	52NiCrMoKU	56NiCrMoV7C100K	----	----	----	244	102	800÷1030
	C100KU	C100W1	----	BS 1	S-1	212	96	710÷980
	X210Cr13KU	X210Cr12	Z200C12	BD2-BD3	D6-D3	252	103	820÷1060
	58SiMo8KU	----	Y60SC7	----	S5	244	102	800÷1030
Stainless steels	X12Cr13	4001	----	----	410	202	94	670÷885
	X5CrNi1810	4301	Z5CN18.09	304 C 12	304	202	94	590÷685
	X8CrNi1910	----	----	----	----	202	94	540÷685
	X8CrNiMo1713	4401	Z6CDN17.12	316 S 16	316	202	94	490÷685
Copper alloys Special brass Bronze	Aluminium copper alloy G-CuAl11Fe4Ni4 UNI 5275					220	98	620÷685
	Special manganese/silicon brass G-CuZn36Si1Pb1 UNI5038					140	77	375÷440
	Manganese bronze SAE43 - SAE430					120	69	320÷410
	Phosphor bronze G-CuSn12 UNI 7013/2a					100	56,5	265÷314
Cast iron	Gray pig iron		G25			212	96	245
	Spheroidal graphite cast iron		GS600			232	100	600
	Malleable cast iron		W40-05			222	98	420

8.2 NOISE TESTS

The test was held under environmental noise levels of 65db. Noise measurements with the machine operating unload was 71db. Noise level during the cutting of mild carbon steel was 73db.

NOTE: with the machine operating, the noise level will vary according to the different materials being processed. The user must therefore assess the intensity and if necessary provide the operators with the necessary personal protection, as required by Law 277/1991.

Control Circuit Diagram

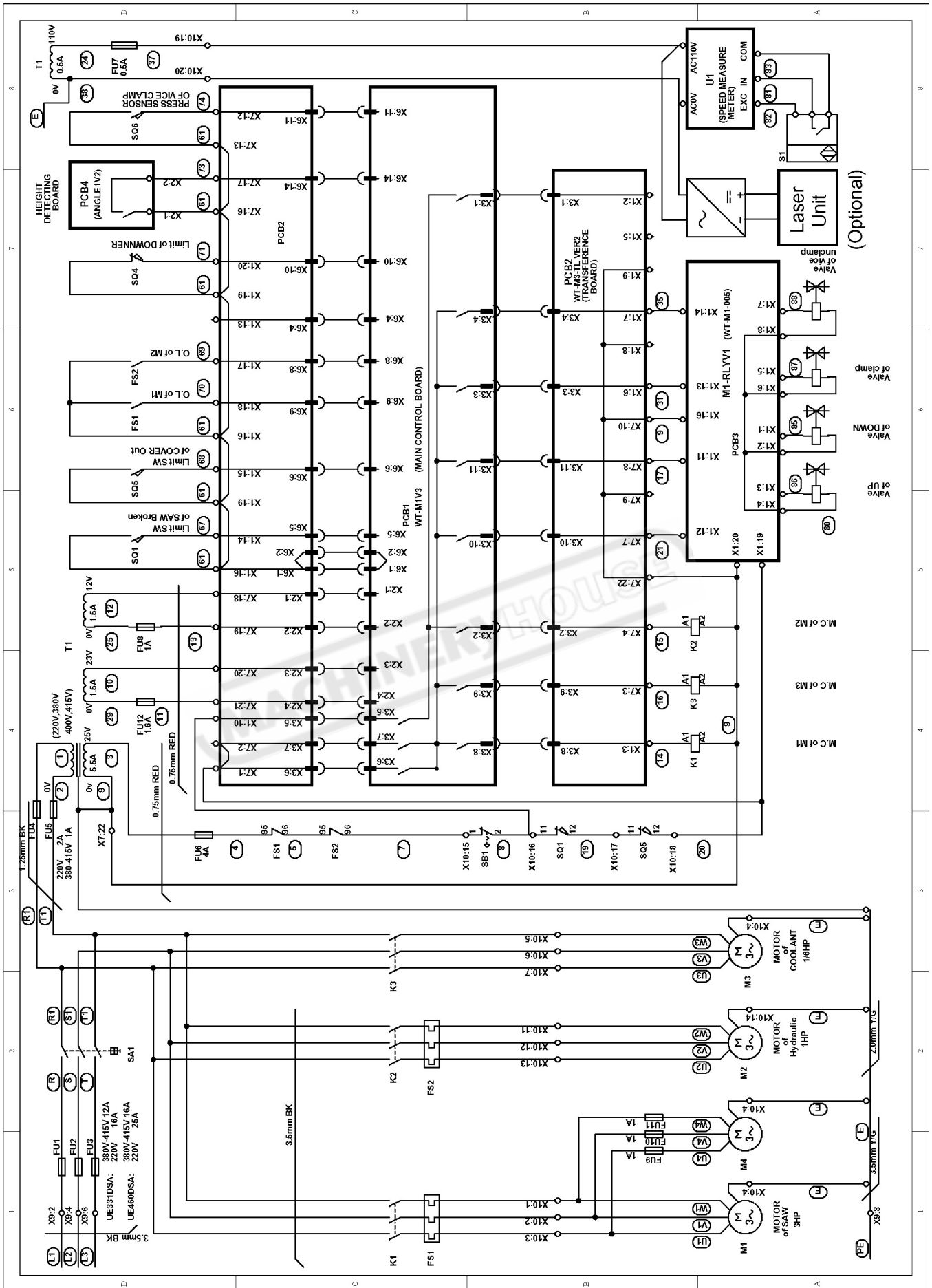

PANEL BOARD WIRING DIAGRAM

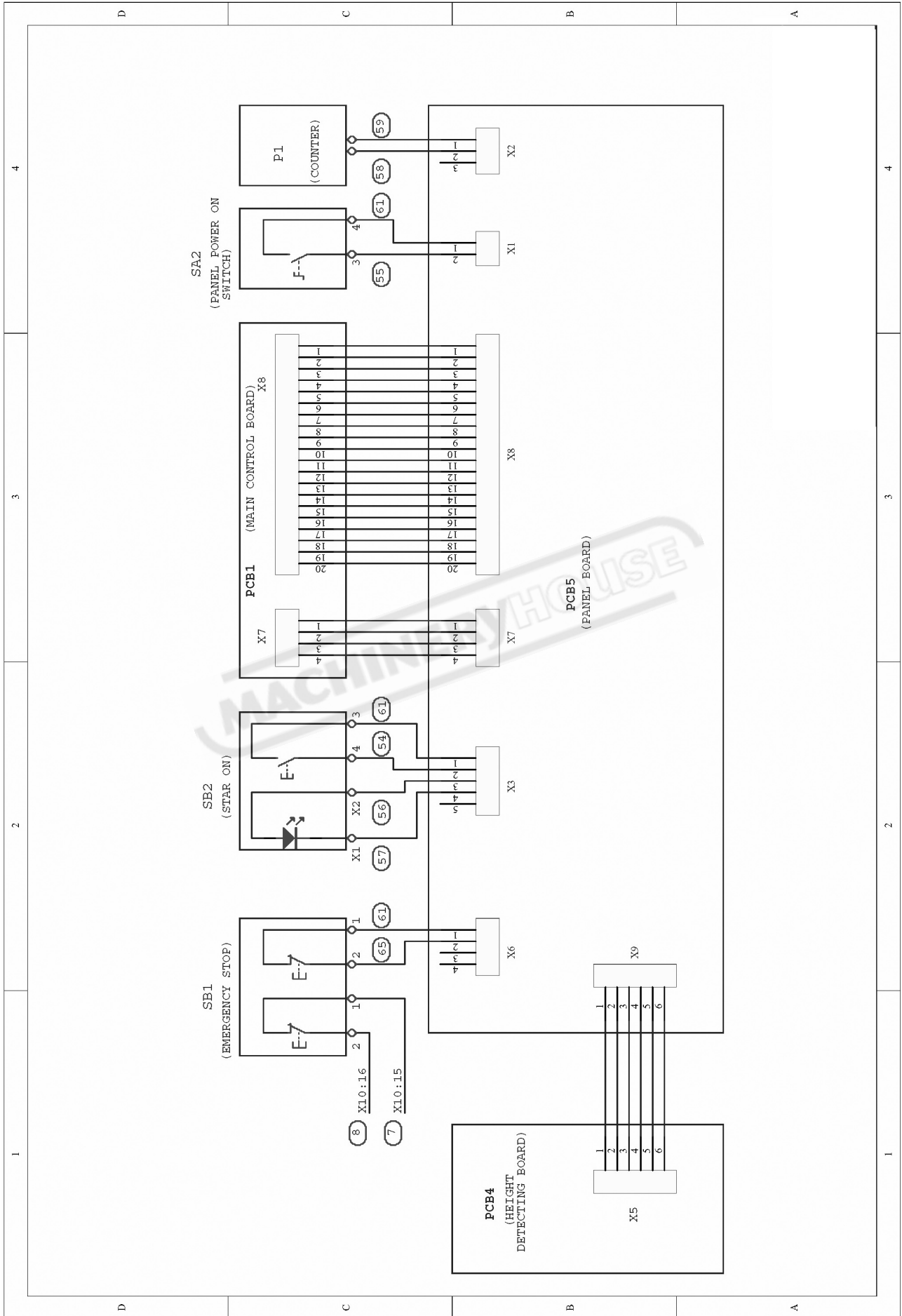

SAW BOW STROKE WIRING DIAGRAM

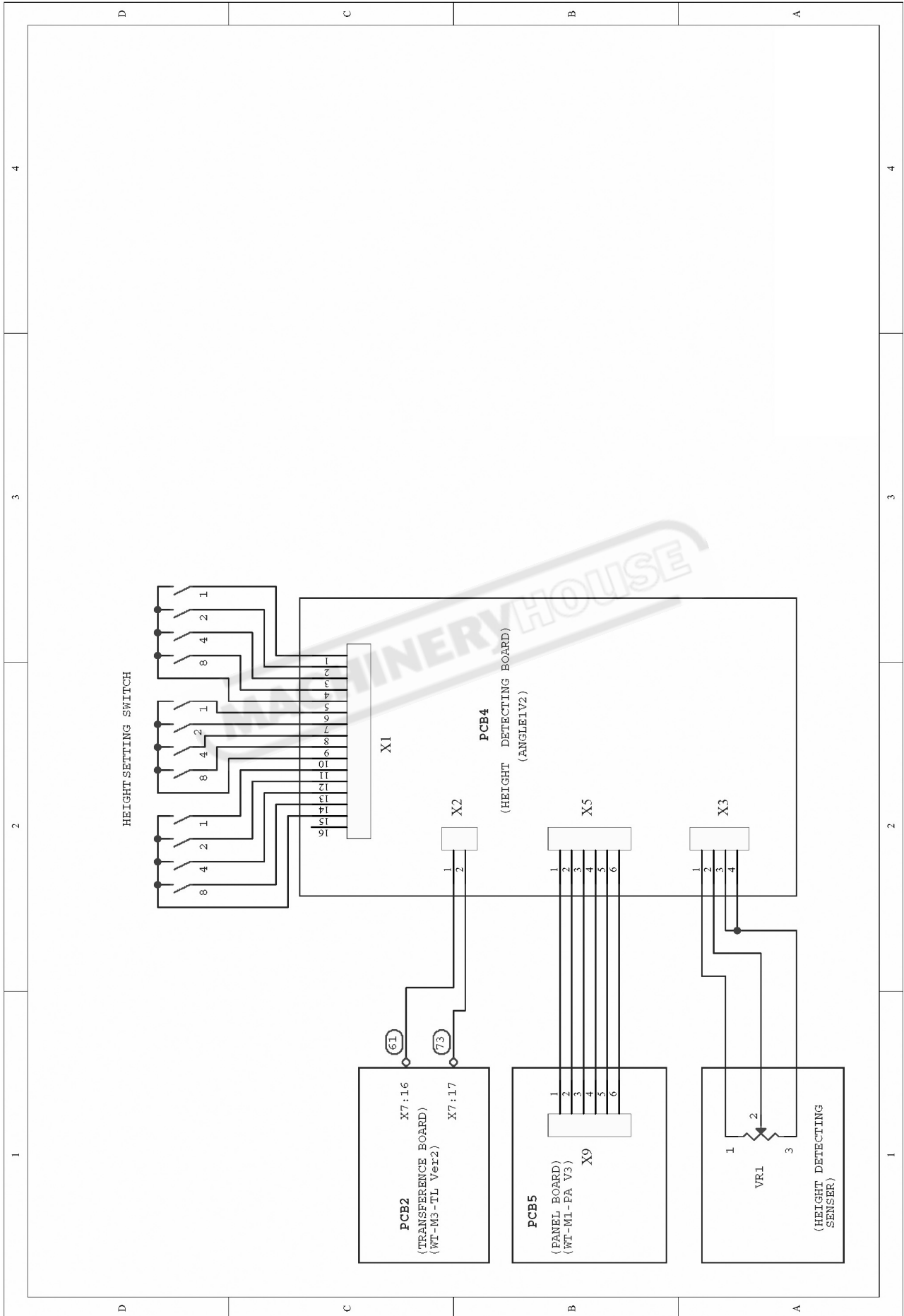

PART LIST

Part No.	Description	Size No.	Q'ty	Part No.	Description	Size No.	Q'ty
1	Base		1	52	Contactora	A9-40-00 (COIL: AC24V)	2
2	Hex. Cap Bolt	M8x20	12	52A	Contactora (Not shown, Non CE)	C09D10A7 (COIL: AC24V)	2
3	Spring Washer	M8	12	53	Contactora	A12-30-10 (COIL: AC24V)	1
4	Washer	M8	12	53A	Contactora (Not shown, Non CE)	C12D10A7 (COIL: AC24V)	1
5	Supporter		1	54	Fuse Seat	10x38-1P	2
6	Set Screw	M6x6	4	55	Fuse Seat	ASK2S / (5X20-1P)	3
7	Hex. Socket Cap Screw	M6x12	4	55A	Fuse Seat (Not shown, Non CE)	6X30-1P	3
8	Bracket		6	56	Transformer	CE-250VA	1
9	Nut	M8	12	57	Relay PC Board	M1-RLY	1
10	Spring Washer	M8	12	58	Connector PC Board	WT-M3-TL	1
11	Washer	M8	12	59	Dual Terminal Connector	ASL-TD-015H	10
12	Front and Rear Tray		2	60	Fuse Seat	10x38-1P	3
13	Hex. Cap Bolt	M8x20	12	61	Ground Terminal Connector	AVK10T	1
14	Chip Drawer		1	61A	Ground Terminal Connector (Not shown, Non CE)	HT-4E	1
15	Side Coolant Tray		1	62	Terminal Connector	AVK10	3
16	Washer	M8	2	62A	Terminal Connector (Not shown, Not CE)	HT-10	3
17	Spring Washer	M8	2	63	Grounding Plate	G-8P	1
18	Hex. Cap Bolt	M8x16	2	64	Overload Contactora	ABB-TA25DU 4.5~6.5A	1
19	Coolant Pump		1	64A	Overload Contactora (Not shown, Non CE)	NTH-4.5~6.5A	1
20	Hex. Cap Bolt	M6x12	2	65	Overload Connector	ABB-TA25DU 1.7~2.4A	1
21	Washer	M6	2	65A	Overload Relay (Not shown, Not CE)	NTH-1.4~1.9A	1
22	Pump Plate		1	67	Electric Box Cover		1
23	Button Head Socket Screw	M6x12	2	68	Power Switch (Upper)	YMXN6	1
24	Plate		1	69	Washer	M6	1
25	Button Head Socket Screw	M6x8	4	70	Spring Washer	M6	1
26	Retrieving Ramp		1	71	Hex. Socket Cap Screw	M6x30	1
27	Washer	M12	6	72	Hinges	Ø8x50	2
28	Spring Washer	M12	6	73	Main PC Board	WT-M1	1
29	Hex. Cap Bolt	M12x20	6	74	Control Panel		1
30	Side Plate		1	74-1	Control PCB		1
31	Washer	M8	3	75	Counter		1
32	Spring Washer	M8	3	76	Button Head Socket Screw	M5x8	10
33	Hex. Cap Bolt	M8x16	3	77	Key Lock Power Switch		1
34	Washer	M8	2	78	Cutting Feed Rate		1
35	Spring Washer	M8	2	79	Cycle Start Switch		1
36	Hex. Cap Bolt	M8x16	2	80	Emergency Stop Button		1
37	Hydraulic Unit		1	81	Stroke Panel		1
38	Hex. Cap Bolt	M8x16	2	81-1	Bow Height PCB		1
39	Front Plate		1	82	Stroke Height Switch		1
40	Button Head Socket Screw	M6x8	4	83	Button Head Socket Screw	M5x8	4
41	Hex. Cap Bolt	M12x70	4	84	Plate		1
42	Nut	M12	4	85	Handle		2
43	Rear Plate		1	86	Button Head Socket Screw	M5x8	4
44	Button Head Socket Screw	M6x8	4	87	Control Box		1
45	Vise Pressure Adjusting Valve		1	98	Plate		1
46	Electrical Box		1	99	Button Head Socket Screw	M5x8	4
47	Washer	M6	4	100	Shaft		1
48	Hex. Socket Cap Screw	M6x16	4	101	Bearing	6000ZZ	1
49	Electrical Plate		1	102	Spring Washer	M10	1
50	Hex. Socket Cap Screw	M6x12	4	103	Nut	M10	1
51	Power Switch (Seat)	XA323B/B-40A	1	104	Cam Seat		1

PART LIST

Part No.	Description	Size No.	Q'ty	Part No.	Description	Size No.	Q'ty
105	Button Head Socket Screw	M8x25	2	156	Nut	M20	1
106	C Ring	S16	1	157	Hex. Cap Bolt	M10x60	1
107	Hex. Socket Cap Screw	M10x40	1	158	Nut	M10	1
108	Extend Spring		1	159	Screw Holder		1
109	Nut	M10	1	160	Spring Bracket		1
110	Joint Plate		1	161	Washer	1/2	1
111	Set Bolt		1	162	Nut	1/2	1
112	Connect Unit		1	163	Spring Washer	M8	4
113	Hex. Socket Cap Screw	M10x50	1	164	Hex. Socket Cap Screw	M8x25	4
114	Handle Level		1	165	Cutting Bench		1
115	Nut	M12	1	166	Pin	Ø8x20	2
116	Handle		1	167	Hex. Socket Cap Screw	M10x60	2
117	Angle Setting		1	168	Cutting Plate		1
118	Hex. Socket Cap Screw	M8x20	2	169	Hex. Socket Cap Screw	M8x55	2
119	Set Block		1	170	Hex. Socket Cap Screw	M8x20	2
120	Button Head Socket Screw	M6x8	2	171	Vise Jaw-Left		1
121	Cover		1	172	Vise jaw-Right		1
122	Hex. Socket Cap Screw	M10x40	1	173	Hex. Socket Cap Screw	M10x30	8
123	Washer		1	174	Hex. Socket Cap Screw	M8x20	4
124	Angle Wheel		1	175	Vise Plate		1
125	Wire Connector		1	176	Hex. Socket Cap Screw	M8x20	1
126	Hex. Cap Bolt	M5x15	1	177	Hex. Socket Cap Screw	M12x30	2
127	Bush		1	178	Vise Jaw		1
128	Steel Wire	Ø1.2x1240	1	179	Vise Slide		1
129	Extend Spring		1	180	Cylinder		1
130	Bed Plate		2	181	Hex. Socket Cap Screw	M12x30	2
131	Pin	Ø8x20	4	182	Hex. Socket Cap Screw	M10x40	4
132	Hex. Socket Cap Screw	M12x70	4	183	Vise Bench		1
133	Set Screw	M12x30	4	184	Bench Supporter		1
134	Bed		1	185	Nut		1
135	Nut	M10	1	186	Spring Washer	M10	2
136	Hex. Socket Cap Screw	M10x40	1	187	Hex. Socket Cap Screw	M10x25	2
137	Seating Block		2	188	Washer	M10	1
138	Hex. Socket Cap Screw	M10x35	4	189	Bearing	6200ZZ	1
139	Hex. Socket Cap Screw	M10x20	5	190	Spring Washer	M10	2
140	Spring Washer	M10	5	191	Hex. Socket Cap Screw	M10x30	1
141	Pin	Ø8x20	2	192	Handle		1
142	Angle Plate		1	193	Handle Rod		1
143	Lower Cover		1	194	Nut	M10	1
144	Hex. Socket Cap Screw	M8x20	8	195	Adjusting Part		1
145	Hex. Cap Bolt	M5X15	1	196	Set Screw	M8x8	2
146	Wire Connector		1	197	C Ring	S17	2
147	Swiveling		1	198	Shaft		1
148	Shaft		1	199	Key	5x5x20	1
149	Taper Bearing	30312	2	200	Cam		1
150	Upper Cover		1	201	Hex. Socket Cap Screw	M6x16	1
151	Set Screw	M6x25	1	202	Hex. Cap Bolt	M6x16	1
152	Hex. Socket Cap Screw	M8x20	8	203	Nut	M6	1
153	Tighten Plate		1	204	Bolt		1
154	O Ring	ØP60	2	205	Hex. Socket Cap Screw	M8x40	2
155	Hex. Cap Bolt	M20x65	1	206	Spring Washer	M8	2

PART LIST

Part No.	Description	Size No.	Q'ty	Part No.	Description	Size No.	Q'ty
207	Washer	M8	2	257	Drive Wheel		1
208	Set Block		1	258	Washer		1
209	Set Screw	M8x8	2	259	Flat Head Hex. Soc. Screw	M12x25	1
210	Set Block		1	260	Button Head Socket Screw	M6x12	2
211	Copper Parts		2	261	Flat Head Hex. Soc. Screw	M4x10	2
212	Vise Guide		1	262	Cover Location Seat		1
213	Hex. Socket Cap Screw	M12x35	4	263	Cover Location Inlet		1
214	Plate		1	264	Block		1
215	Spring Washer	M8	2	265	Button Head Socket Screw	M8x40	2
216	Hex. Cap Bolt	M8x20	2	266	Button Head Socket Screw	M6x20	4
217	Retrieval Vise		1	267	Set Block		2
218	Set Handle	M8x30	2	268	Pin	Ø5x50	2
219	Round Head Screw	M6x8	2	269	Taper Bearing	32007	2
220	Handle		1	270	Idle Wheel		1
221	Handle Seat		1	271	Anti-Dust Cover	Ø35	2
222	Pin	Ø6x28	1	272	Star Washer	AW07	1
223	Screw Sleeve		1	273	Nut		1
224	Set Handle	M12x45	1	274	Hex. Cap Bolt	M8x60	1
225	Rod		1	275	Nut	M8	1
226	Set Screw	M8x8	1	278	Disc Washer		8
227	Sleeve Rod		1	279	Plate		1
228	Shaft		1	279-1	Bushing		1
229	Mobile Fence		1	279-2	Blade Tension Gauge		1
230	Set Screw	M8x8	1	279-3	Bearing	51203	1
231	Blade Cover		1	282	Set Screw	M8x10	1
231-1	Button Head Socket Screw	M5x8	2	283	Handle Wheel		1
232	Button Head Socket Screw	M6x12	4	284	Handle		1
233	Free Set		2	285	Slide Bolt		1
234	Flat Head Hex. Soc. Screw	M4x10	2	286	Washer		1
235	Cover Set		1	287	C Ring	S35	2
236	Wire Brush Guard		1	288	Shaft	Ø14x70	1
237	Button Head Socket Screw	M5x8	2	289	Slide		1
238	Hex. Socket Cap Screw	M6x16	1	290	Shaft Device		1
239	Washer	M6	1	291	Oil Nozzle	1/16"	1
240	Washer		1	292	Set Screw	M12x25	1
241	Brush Drive Wheel		1	293	Blade Cover		1
242	Sleeve		1	294	Button Head Socket Screw	M5x8	4
243	Set Screw	M6x6	3	295	Cover Switch		1
244	Set Bush		2	296	Hex. Socket Cap Screw	M4x30	2
245	Brush Rod		1	297	Slide Guide		2
246	Brush Bracket		1	298	Slide Plate		2
247	Hex. Socket Cap Screw	M8x40	1	299	Spring Washer	M10	6
248	Shaft		1	300	Hex. Socket Cap Screw	M10x55	6
249	Hex. Socket Cap Screw	M6x8	2	301	Limit Switch		1
250	Set Tube		1	302	Hex. Socket Cap Screw	M4x35	2
251	Brush		1	303	Saw Bow Cylinder		1
252	Washer	M6	1	304	C Ring	S16	4
253	Nut	M6	1	305	Cylinder Seat		1
254	Saw Bow		1	306	Lower Shaft		1
255	Spring Washer	M12	4	307	Hex. Socket Cap Screw	M8x20	2
256	Hex. Cap Bolt	M12x40	4	308	Holder		1

PART LIST

Part No.	Description	Size No.	Q'ty	Part No.	Description	Size No.	Q'ty
309	Upper Shaft		1	362	Pin	Ø4x12	1
310	Limit Switch		1	363	Adjustable Bracket-Right		1
311	Hex. Socket Cap Screw	M4x30	2	364	Hex. Socket Cap Screw	M8x30	2
312	Indicator Seating		1	365	Pipe Fitting	1/4PTx1/4	2
313	Button Head Socket Screw	M5x8	2	366	On/Off Valve	1/4"	2
314	Washer		1	367	Button Head Socket Screw	M6x8	2
315	Hex. Socket Cap Screw	M12x65	4	368	Set Plate		1
316	Set Block		1	369	Hex. Socket Cap Screw	M8x25	4
317	Hex. Cap Bolt	M10x20	1	370	Spring Washer	M8	4
318	Nut		1	371	Set Screw	M8x16	6
319	Spring Washer		1	372	Adjustable Screw		2
320	Washer		1	373	Spring		2
321	Sensor Bracket		1	374	Shaft		2
322	Sensor		1	375	Guide Bracket-Right		1
323	Round Head Screw	M4x10	2	376	Bearing Shaft-Short		2
324	Cover		1	377	Bearing Shaft-Long		2
325	Button Head Socket Screw	M5x8	4	378	Set Screw	M12x10	2
326	Gear Box		1	379	Hex. Socket Cap Screw	M6x16	2
327	Key	12x8x50	1	380	Set Guide		2
328	Side Cover		1	381	Adjustable Bracket-Left		1
329	Button Head Socket Screw	M5x8	3	382	Lock Handle	M8x30	2
330	Motor		1	383	Adjusting Guide		2
331	Washer	M8	4	384	Pipe Fitting		1
332	Spring Washer	M8	4	385	On/Off Valve	1/4"	1
333	Hex. Cap Bolt	M8x30	4	386	Pipe Fitting	1/4x1/4PT	2
334	Set Plate		1	387	Guide Bracket-Left		1
335	Washer	M6	2	388	Bearing	6000ZZ	2
336	Spring Washer	M6	2	389	Washer	M10x19x2	2
337	Hex. Socket Cap Screw	M6x12	2	390	Bearing	6200ZZ	4
338	Round Head Screw	M3x20	2	391	Spring Washer	M10	4
339	Sensor		1	392	Nut	M10	4
340	Nut	M3	2	393	Bush	Ø10x19x19	2
341	Key	10x8x40	1	394	Blade Guide-Left		1
342	Pulley Cover		1	395	Knob	M5x8	1
343	Button Head Socket Screw	M5x8	4	396	Pin	Ø4x12	1
344	Belt	1922V426	1	397	Cover		1
345	Input Pulley		1	398	Round Head Screw	M6x8	6
346	Hex. Socket Cap Screw	M8x65	1	399	Control Box Bracket		1
347	Variable Speed Adjustable		1	400	Button Head Socket Screw	M6x8	4
348	Cover		1	401	Swiveling Bracket		1
349	Button Head Socket Screw	M5x8	7	402	Hex. Socket Cap Screw	M6x16	4
350	Nut	1/2"	2	403	Hex. Cap Bolt	M8x16	4
351	Washer	1/2"	2	404	Spring Washer	M8	4
352	Spring Bracket		1	405	Handle	M8x35	1
353	Spring Washer	M10	2	406	Swiveling Base		1
354	Hex. Socket Cap Screw	M10x25	2	407	Set Screw	M8x20	2
355	Tension Spring		1	408	Nut	M8	2
356	Brackets Slide		1	409	Connect Base		1
357	Set Screw	M10x16	10	410	Spring Washer	M8	4
358	Lock Block		2	411	Hex. Cap Bolt	M8x16	4
359	Hex. Socket Cap Screw	M10x20	10	412	Cover		1
360	Blade Guide-Right		1	413	Round Head Screw	M6x8	4
361	Knob	M5x8	1				

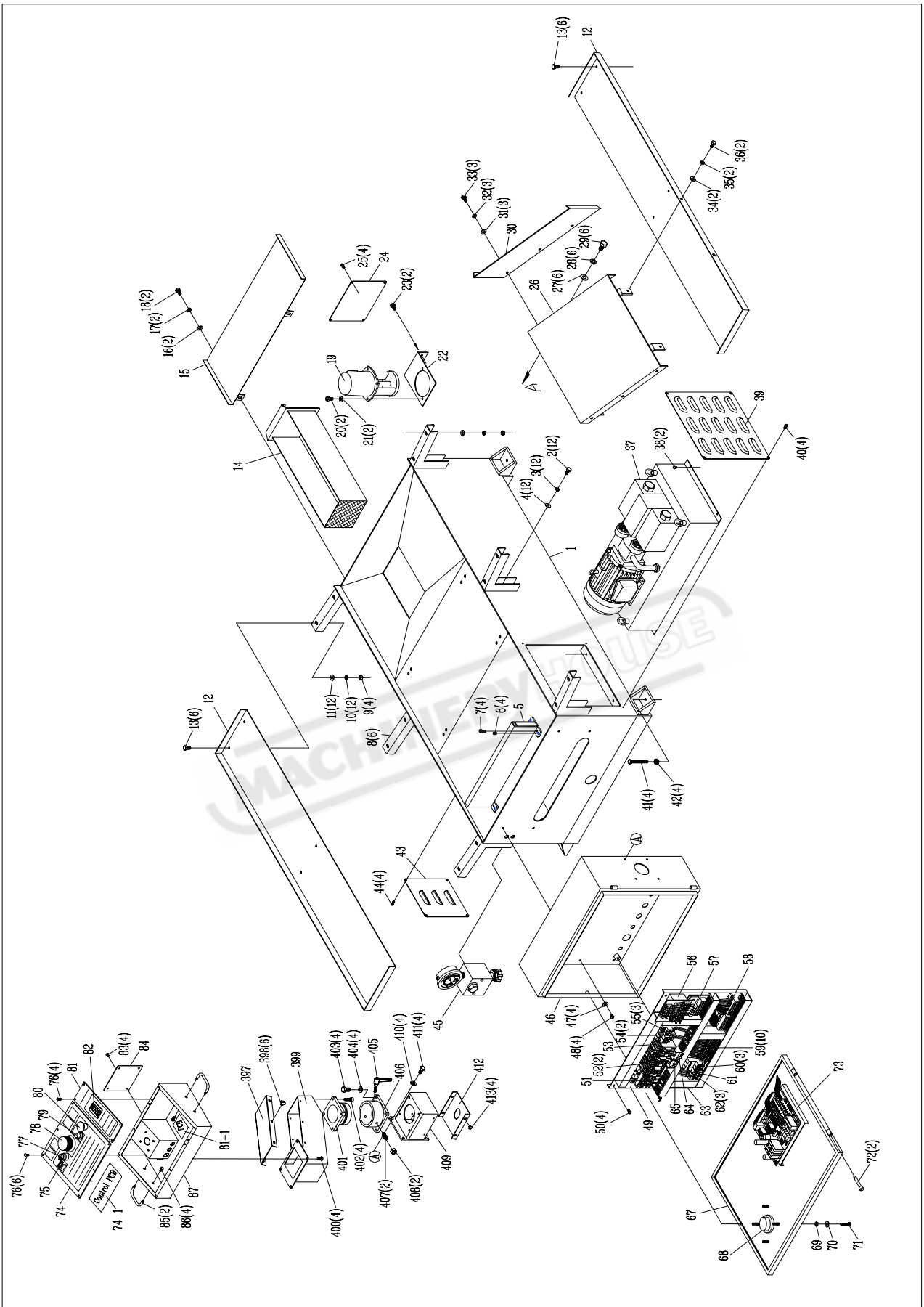

950509-V4

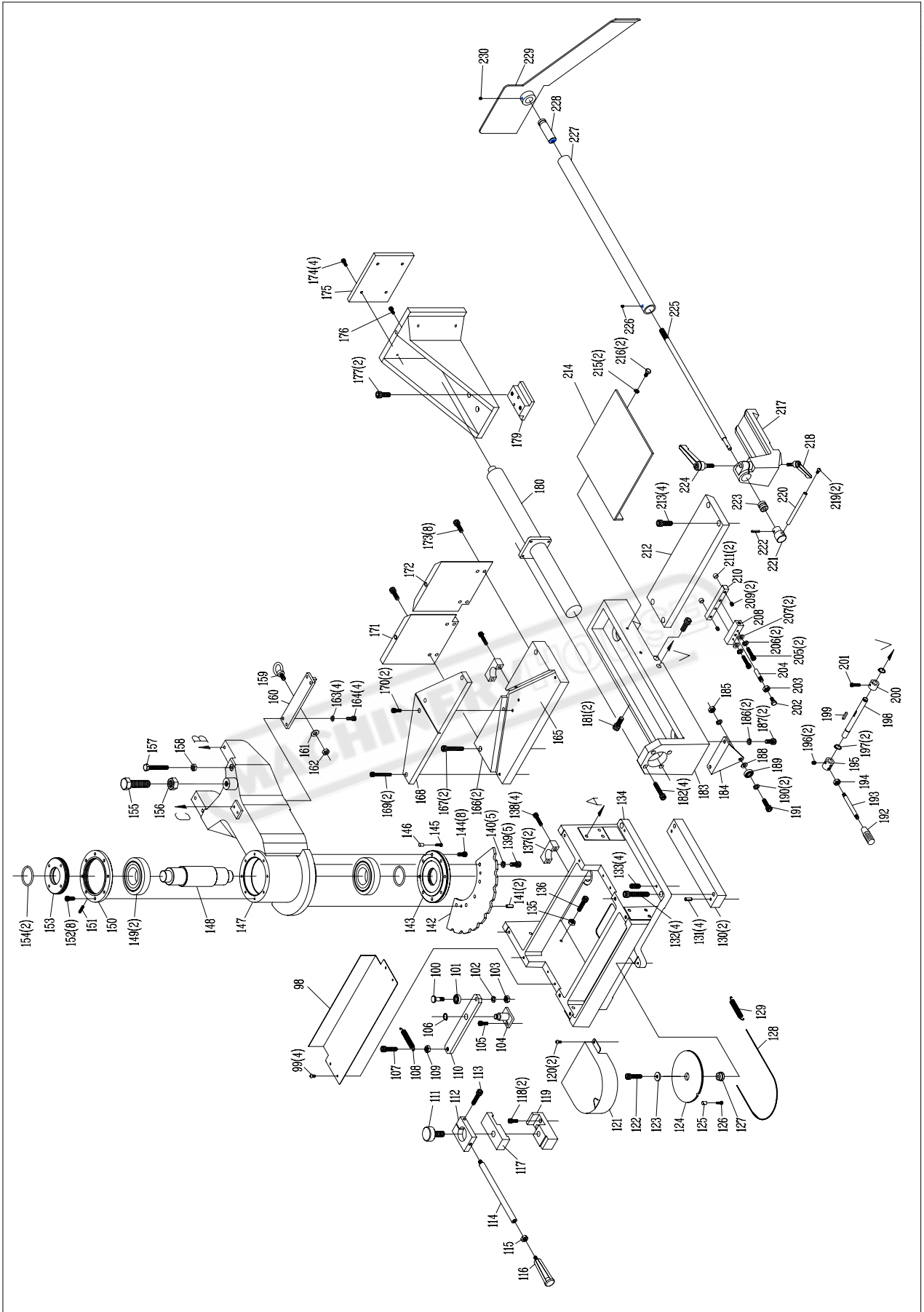

930407-VI

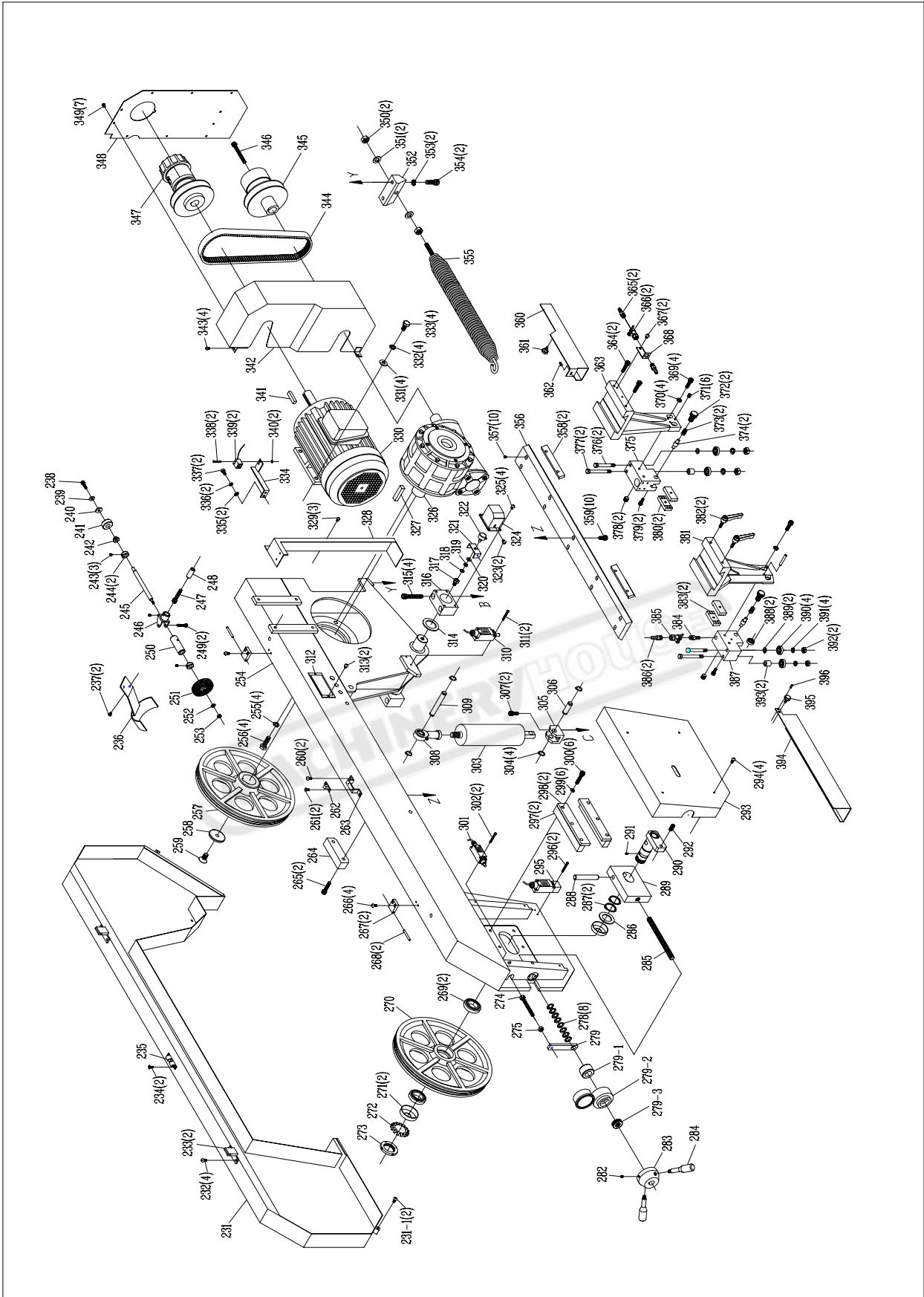

940518-V3